

Pure reliability and performance

Discover the
new features
and
adaptations



FOLDING-GLUING | FOLDING CARTON

NOVAFOLD 50 | 80 | 110

At a glance

Empowering flexibility

The reliable, precise and versatile folder-gluer exceeds your needs. The **NOVAFOLD** allows you to produce a wide range of box styles, in different materials, at speeds of up to 300 meters per minute. Easy to operate, the folder-gluer delivers consistent and superb end-product quality.

NOVAFOLD 50 | 80 | 110

- > At a glance
- > Packaging market
- > Benefits and features
 - > 1-3
 - > 4-6
 - > 7-9
- > Specifications
 - > Measurements
 - > Configurations
 - > Technical information
- > Related products
- > Services
 - > General services
 - > BOBST Connect

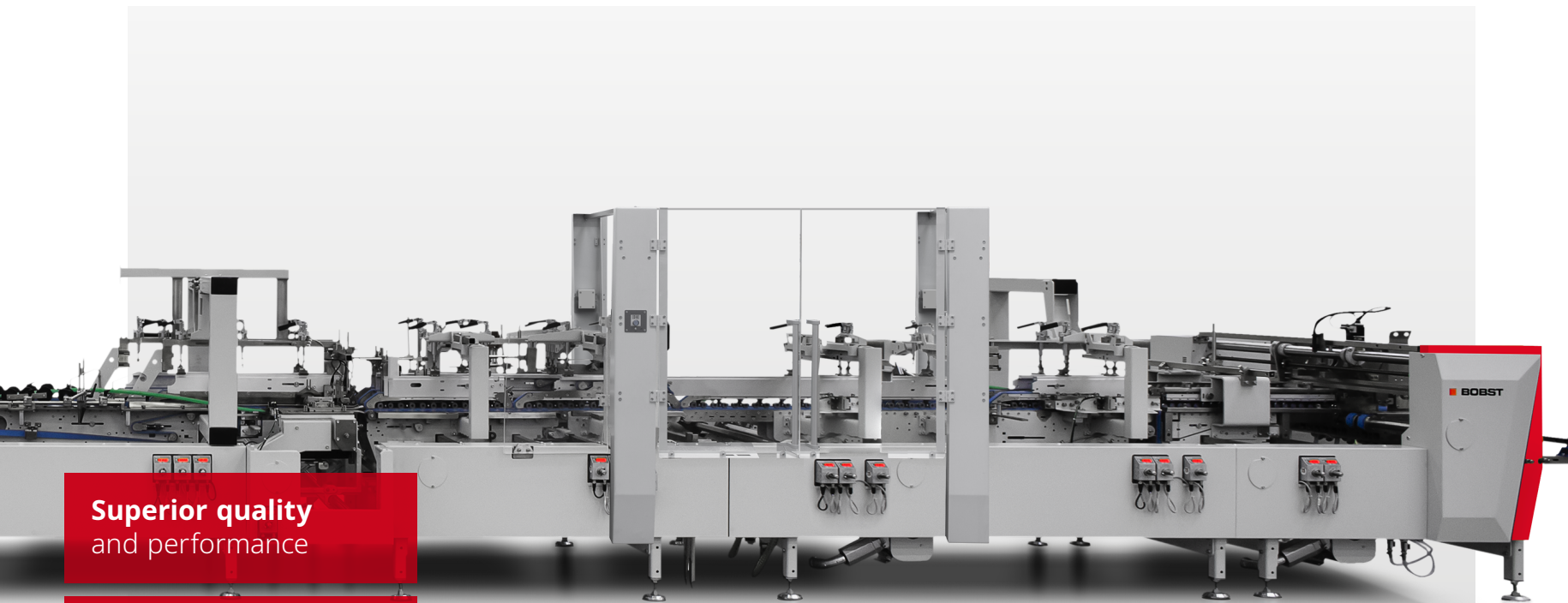

Superior quality
and performance

Opening commercial
opportunities

User-friendly
ergonomics

[> WATCH VIDEO](#)

[REQUEST
CONSULTING](#)

 [Print responsibly](#)

Data is not binding.
Non-contractual pictures.
The manufacturer reserves
the right to make
modifications without notice.
© BOBST SA 2022
BUPC-NFD110-EN-0722

Increased efficiency

True to its vision to advance Connectivity and Digitalisation, the machine control platform SPHERE has been integrated on the NOVAFOLD 50 | 80 | 110. Together with the redesigned Combifolder security doors, the NOVAFOLD is even more operator-friendly, compact and ready for a full transition to a digitalized and connected workflow.

HMI SPHERE



HMI SPHERE control platform ensures that current and future
> BOBST Connect functions can be used to the full



SPHERE provides an intuitive and self-explanatory machine overview for quick job setups

Combifolder



Combifolder doors give maximum accessibility to the 4&6-corner and adjacent modules



Cross bars allow to fix and store tools, making them quickly available



Leaner safety equipment reduces the footprint at the back of the machine

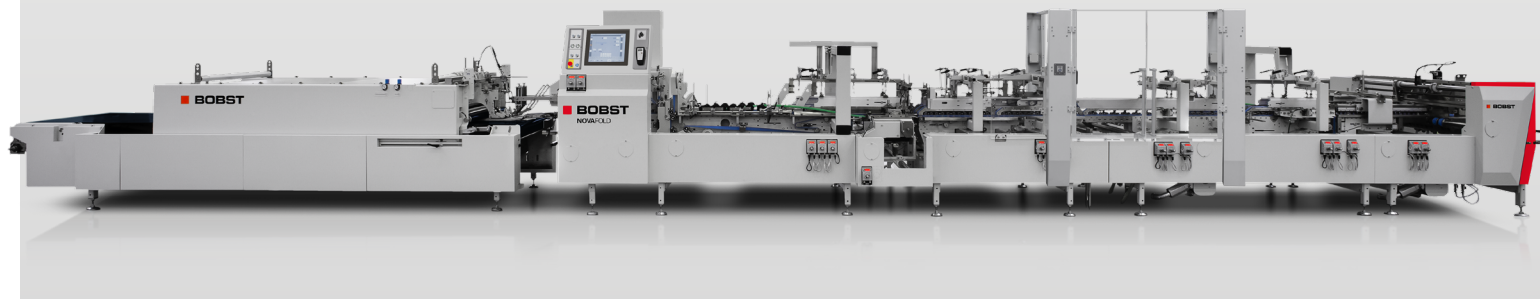

NOVAFOLD 50 | 80 | 110

- > At a glance
- > Packaging market
- > Benefits and features
 - > 1-3
 - > 4-6
 - > 7-9
- > Specifications
 - > Measurements
 - > Configurations
 - > Technical information
- > Related products
- > Services
 - > General services
 - > BOBST Connect

**REQUEST
CONSULTING**

Print responsibly

Data is not binding.
Non-contractual pictures.
The manufacturer reserves the right to make modifications without notice.
© BOBST SA 2022
BUPC-NFD110-EN-0122

Creating value

BOBST innovations
are driven by customer
and brand owner needs.

[> READ MORE](#)

Functional packaging and protection

Protecting the goods in a clever way is required. Single serve, multi-packs, re-sealable, see-through.

Customization, versioning, personalization

Packaging needs to reach all segments of the society taking almost any shape and size from very short runs to reprint and long runs. All with the best color consistency.

E-commerce & omni-channels

Multiple retail formats set new requirements for packaging. On-demand production, timely delivery across multiple designs, shapes and sizes.

Sustainability

Packaging production needs to reduce its environmental carbon footprint – less waste across the entire supply chain. New and thinner substrates. Recycling and re-use are the new rules.

Faster time-to-market

A growing number of products need to reach consumers faster. Product lifetime is shorter. From product design to the consumer experience, the supply chain has to be more agile.



NOVAFOLD 50 | 80 | 110

- > At a glance
- > Packaging market
- > Benefits and features
 - > 1-3
 - > 4-6
 - > 7-9
- > Specifications
 - > Measurements
 - > Configurations
 - > Technical information
- > Related products
- > Services
 - > General services
 - > BOBST Connect

Print responsibly

Data is not binding.
Non-contractual pictures.
The manufacturer reserves
the right to make
modifications without notice.
© BOBST SA 2022
BUPC-NFD110-EN-0722



Highly reliable feeding

Feeder & blank aligner

- Handles most types of materials and box styles for high versatility
- Optional blank aligner for perfect folding precision
- Variable speed independent drive enabling a wide range of speed settings
- Quick and rapid set-up for easy repeatability



Accurate prebreaking

Prebreaker

- 180° prebreaking of all boxes at high speed, regardless of the material
- Long prebreaker for perfectly flat glue flaps
- Extra-wide lower left-hand belt ensures no marking
- High-speed re-opening plough
- Upper left conveyor displacement allows for more flexibility



Flexible and time-saving

Crash-lock module

- Processes multiple-fold packaging
- Prebreaks large boxes and provides a location for supplementary devices such as label inserters
- Telescopic upper conveyors easily adjustable to box format
- Allows for front panel folding

NOVAFOLD 50 | 80 | 110

- > At a glance
- > Packaging market
- > Benefits and features
 - > 1-3
 - > 4-6
 - > 7-9
- > Specifications
 - > Measurements
 - > Configurations
 - > Technical information
- > Related products
- > Services
 - > General services
 - > BOBST Connect

 Print responsibly

Data is not binding.
Non-contractual pictures.
The manufacturer reserves the right to make modifications without notice.
© BOBST SA 2022
BUPC-NFD110-EN-0722



Versatility and speed

4 & 6-corner device

- Fast set-up of all types, and most sizes, of 4 and 6-cornered boxes
- Speeds of up to 18,000 b/h
- Tilting frame adjusts to flap size
- Cable guides for 45° panel
- HMI SPHERE control allows for saving of settings, automated positioning and remote control
- Modulated hook trajectory for high speed, high quality production
- Transparent security doors, reducing footprint at the back of the machine and offering space for tool storage



Precise glue application

Lower gluing unit

- Oversized stainless steel glue wheel for high-speed running
- Unique scraper device with micro-metric adjustment for precise gluing
- All components easily removable for quick cleaning



Excellent control

Folding

- Minimum folding device for folding down to 35 mm
- Choice of left, right or simultaneous folding
- Automatic belt tensioning ensures quicker makeready

NOVAFOLD 50 | 80 | 110

- > At a glance
- > Packaging market
- > Benefits and features
 - > 1-3
 - > 4-6
 - > 7-9
- > Specifications
 - > Measurements
 - > Configurations
 - > Technical information
- > Related products
- > Services
 - > General services
 - > BOBST Connect

 Print responsibly

Data is not binding.
Non-contractual pictures.
The manufacturer reserves the right to make modifications without notice.
© BOBST SA 2022
BUPC-NFD110-EN-0722



Independence and control

Transfer

- Synchronized kicker adjusts to carton arrival time
- Adjustable transfer conveyors adapt to difficult box shapes
- ACCUEJECT or rotary ejector device on demand ejects non-conforming boxes
- Allows delivery from above or underneath for double-wall, 4-corner boxes or boxes with windows



Constant flow

Delivery

- Integrated box stream regulator for precise stream intervals, faster running and less waste
- Automatic apron centering improves box quality and prolongs belt life
- Infeed conveyor for better control of boxes with irregular edges



Smart HMI

HMI SPHERE

- Controls all functions the machine
- Up to two 15" full color, high-definition touch screens
- Simple step-by-step procedure guides the operator through the job set-up process
- All settings appear on one screen for more convenient and intuitive navigation
- Fully compatible with the digital BOBST Connect platform
- Allows the saving of up to 5,000 job settings

NOVAFOLD 50 | 80 | 110

- > At a glance
- > Packaging market
- > Benefits and features
 - > 1-3
 - > 4-6
 - > 7-9
- > Specifications
 - > Measurements
 - > Configurations
 - > Technical information
- > Related products
- > Services
 - > General services
 - > BOBST Connect

 Print responsibly

Data is not binding.
Non-contractual pictures.
The manufacturer reserves the right to make modifications without notice.
© BOBST SA 2022
BUPC-NFD110-EN-0722

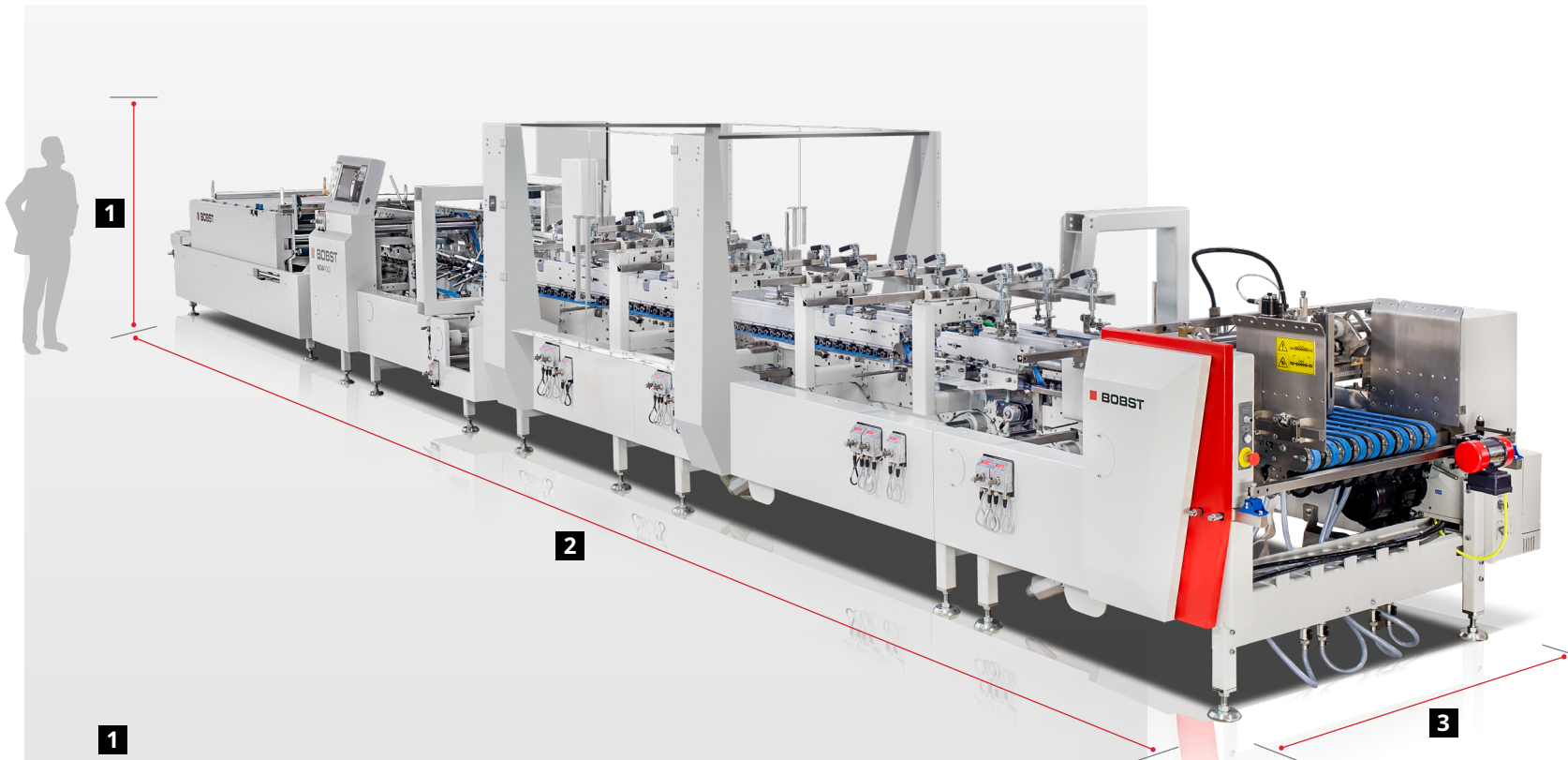

NOVAFOLD 50 | 80 | 110

- > At a glance
- > Packaging market
- > Benefits and features
 - > 1-3
 - > 4-6
 - > 7-9
- > Specifications
 - > Measurements
 - > Configurations
 - > Technical information
- > Related products
- > Services
 - > General services
 - > BOBST Connect

1

NOVAFOLD 50 80 110	2.35 m	7.71 ft
------------------------	--------	---------

2

NOVAFOLD 50 80 110	A1	10.10 m	33.13 ft
NOVAFOLD 80 110	A2	11.22 m	36.81 ft

3

NOVAFOLD 50	1.72 m	5.64 ft
NOVAFOLD 80	2.20 m	7.21 ft
NOVAFOLD 110	2.32 m	7.61 ft

Values may vary according to the configuration.

Print responsibly

Data is not binding.
Non-contractual pictures.
The manufacturer reserves
the right to make
modifications without notice.
© BOBST SA 2022
BUPC-NFD110-EN-0722

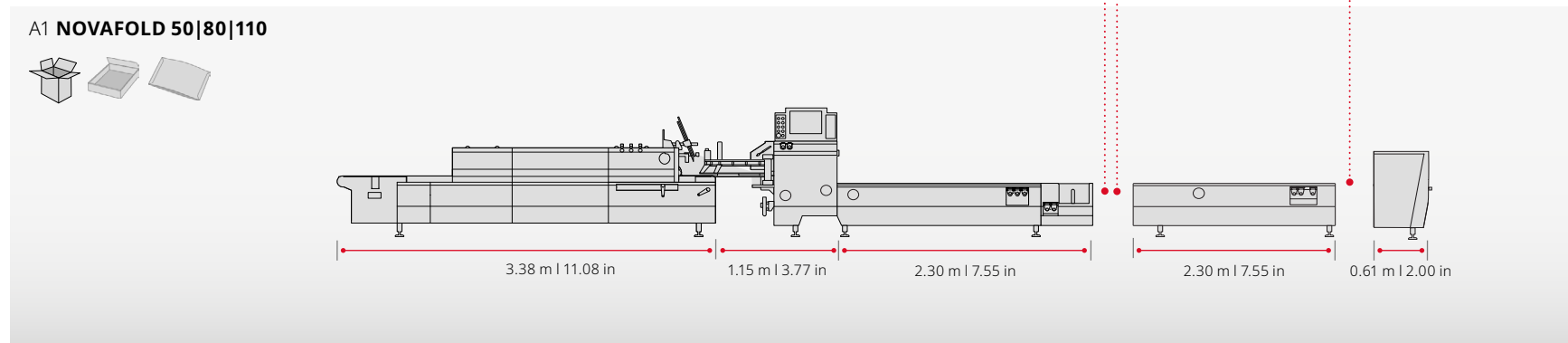
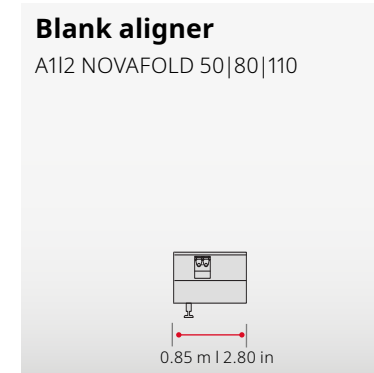
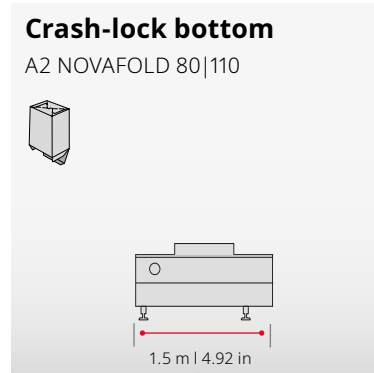
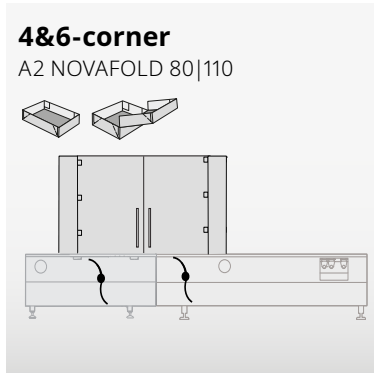

NOVAFOLD 50 | 80 | 110

- > At a glance
- > Packaging market
- > Benefits and features
 - > 1-3
 - > 4-6
 - > 7-9
- > Specifications
 - > Measurements
 - > Configurations
 - > Technical information
- > Related products
- > Services
 - > General services
 - > BOBST Connect

All configurations must be validated by a technical specialist to confirm compatibility of any added.

Print responsibly

Data is not binding.
Non-contractual pictures.
The manufacturer reserves the right to make modifications without notice.
© BOBST SA 2022
BUPC-NFD110-EN-0722

Box sizes

NOVAFOLD 50 | 80 | 110

Straight line boxes (standard folding section)

	Min./mm	Min./inch	Max./mm	Max./inch
C	126	4.96	500 800 1,100	19.68 31.49 43.30
E	60	2.36	800 800 800	31.49 31.49 31.49
L	60	2.36	235 385 535	9.25 15.15 20.27
C with minimum folding device G-001	76	3.00		
L with minimum folding device G-001	35	1.37		

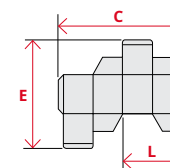

Box sizes

NOVAFOLD 50 | 80 | 110

Crash-lock bottom boxes

	Min./mm	Min./inch	Max./mm	Max./inch
C	146	5.74	500 800 1,100	19.69 31.49 43.30
E¹	60	2.36	800 800 800	31.49 31.49 31.49
E² (depending on box configuration)	60	2.36	800 800 800	31.49 31.49 31.49
L	70	2.75	235 385 535	9.25 15.15 20.27

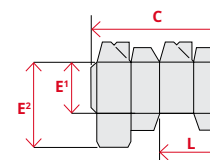

Box sizes

NOVAFOLD 80 | 110

4-corner boxes

	Min./mm	Min./inch	Max./mm	Max./inch
C	120	4.72	800 1,100	31.49 43.30
E	130	5.11	800 800	31.49 31.49
H	20	0.78	150 150	5.90 5.90

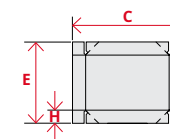

6-corner boxes

	Min./mm	Min./inch	Max./mm	Max./inch
C	250	9.84	800 1,100	31.49 43.30
E	130	5.11	800 800	31.49 31.49
H	30	1.18	114 150	4.48 5.90

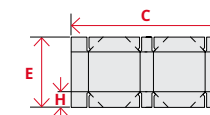

Convertible stock

Carton or solid board, up to	800 g/m ²	.049 in
Corrugated board	N-F-E	N-F-E
Thickness of folded box, max.	12 mm	0.47 in

Drive system

Inching speed	20 m/min	64 ft/min
Operating speed adjustable from	20 - 350 m/min	64 - 1148 ft/min

NOVAFOLD 50 | 80 | 110

- > At a glance
- > Packaging market
- > Benefits and features
 - > 1-3
 - > 4-6
 - > 7-9
- > Specifications
 - > Measurements
 - > Configurations
 - > Technical information
- > Related products
- > Services
 - > General services
 - > BOBST Connect

REQUEST CONSULTING

Print responsibly

Data is not binding.
Non-contractual pictures.
The manufacturer reserves the right to make modifications without notice.
© BOBST SA 2022
BUPC-NFD110-EN-0722

Related products



> **HANDYPACK GT**

An unrivalled multipurpose tool for fast and easy carton collection, using fewer staff at delivery.

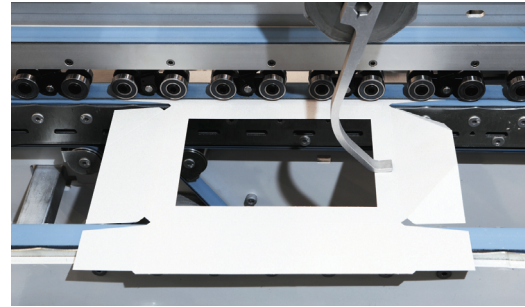

WONDERFOLD

Independent folding hook for folding rear flaps.

NOVAFOLD 50 | 80 | 110

- > At a glance
- > Packaging market
- > Benefits and features
 - > 1-3
 - > 4-6
 - > 7-9
- > Specifications
 - > Measurements
 - > Configurations
 - > Technical information
- > Related products
- > Services
 - > General services
 - > BOBST Connect

 Print responsibly

Data is not binding.
Non-contractual pictures.
The manufacturer reserves
the right to make
modifications without notice.
© BOBST SA 2022
BUPC-NFD110-EN-0722

Maintaining excellence

Expert services for all your equipment.
Improve your processes, boost your productivity and enhance your expertise with a complete range of services from BOBST.



Maintain your Investment

- Scheduled maintenance with BOBST certified technicians
- Preventative intervention, maximizing machine uptime
- Optimum performance over the equipment lifetime

[> WATCH VIDEO](#)

Approved parts and logistics

- BOBST Original and Certified parts, and consumables
- Quality assurance, and extended maintenance intervals
- Worldwide distribution, and full availability where and when you need it

[> LEARN MORE](#)

Machine upgrades

- Additional features, configured for your machine
- Enhanced functionality, connectivity and capability
- Future-proofing your investment, maintaining competitive advantage

[> LEARN MORE](#)

NOVAFOLD 50 | 80 | 110

- > At a glance
- > Packaging market
- > Benefits and features
 - > 1-3
 - > 4-6
 - > 7-9
- > Specifications
 - > Measurements
 - > Configurations
 - > Technical information
- > Related products
- > Services
 - > General services
 - > BOBST Connect

Print responsibly

Data is not binding.
Non-contractual pictures.
The manufacturer reserves the right to make modifications without notice.
© BOBST SA 2022
BUPC-NFD110-EN-0122

Digital age manufacturing happening with BOBST Connect

BOBST Connect is an end-to-end, user-centric digital platform that enhances and increases your packaging productivity. It's designed to help you make the most of the data your machine generates, improving efficiency across your value chain.

As well as exceptional data insights, BOBST Connect helps to orchestrate and improve your whole production process, from your PDF to the finished product and quality report. It brings data and digital services together in one fully connected platform, with machine insights and expertise built in.

All of this is available to you as part of BOBST Connect Essential, the first subscription level that you receive when you purchase a new BOBST machine.



Performance analysis

- Production insights, including interaction of OEE components
- Identify and eliminate performance gaps

Accurate reporting

- Meaningful insights on OEE and downtime
- Accurately measure target speed and quality losses
- Trend analysis over time

Progress indicator

- Highlights extensive production deviations
- Empowers timely interventions

Remote assistance

- Priority access to technical specialists
- Video with Augmented Reality expert support based on real-time data
- Available 24/7 (optional)

Shift management

- Optimize planning time
- Deliver overall resource efficiency

NOVAFOLD 50 | 80 | 110

- > At a glance
- > Packaging market
- > Benefits and features
 - > 1-3
 - > 4-6
 - > 7-9
- > Specifications
 - > Measurements
 - > Configurations
 - > Technical information
- > Related products
- > Services
 - > General services
 - > BOBST Connect

 Print responsibly

Data is not binding.
Non-contractual pictures.
The manufacturer reserves the right to make modifications without notice.
© BOBST SA 2022
BUPC-NFD110-EN-0722

Pure reliability and performance

WWW.BOBST.COM/NOVAFOLD_50-80-110

NOVAFOLD 50 | 80 | 110

- > At a glance
- > Packaging market
- > Benefits and features
 - > 1-3
 - > 4-6
 - > 7-9
- > Specifications
 - > Measurements
 - > Configurations
 - > Technical information
- > Related products
- > Services
 - > General services
 - > BOBST Connect

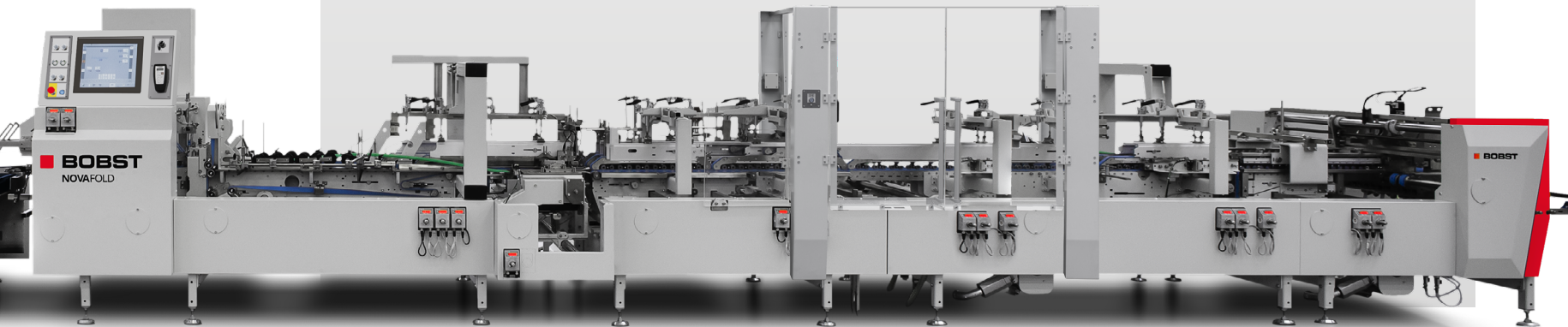

**REQUEST
CONSULTING**

 Print responsibly

Data is not binding.
Non-contractual pictures.
The manufacturer reserves
the right to make
modifications without notice.
© BOBST SA 2022
BUPC-NFD110-EN-0722