

Market-leading excellence



LAMINATED BOARD

EXPERTFLUTE TOUCH

At a glance

Boosting productivity

The most suitable in-line laminator for mature markets with high volumes and precise tolerance demands. The **EXPERTFLUTE TOUCH** can be set up in minutes and delivers efficient and reliable non-stop production of outstanding quality products.

BOBST

EXPERTFLUTE TOUCH

- > At a glance
- > Packaging market
 - > Corrugated board
 - > Folding carton
- > Benefits and features
 - > 1-3
- > Specifications
 - > Measurements
 - > Configurations
 - > Technical information
 - > 3D view
- > Related Products
- > Services
 - > General services
 - > Bobst Connect

Incredible
Versatility

Amazing
Board quality

Maximum
Performance

**REQUEST
CONSULTING**

 Print responsibly

Data is not binding.
Non-contractual pictures.
The manufacturer reserves
the right to make modifica-
tions without notice.
© BOBST S.A. 2023
BUSF-EXFLU-EN-1123

Creating value

BOBST innovations
are driven by customer
and brand owner needs.

[> READ MORE](#)

Good protection and safety

Protecting the goods is the main requirement for corrugated boxes meaning high quality, clever designs, robustness and zero-fault.

Customized, premium, secured

Boxes play a new role where customization, high-graphics and security features are required.

Out of the box experience

Consumers expect the most relevant un-boxing of any goods. Packages are becoming more clever, telling a story as part of the brand positioning.

e-commerce

The demand is growing and is here to stay. Boxes need to come in almost any size and shape, requiring flexibility and productivity across the supply chain.

Sustainability

Packaging production needs to reduce its environmental carbon footprint – less waste across the entire supply chain. New and thinner substrates. Recycling and re-use are the new rules.

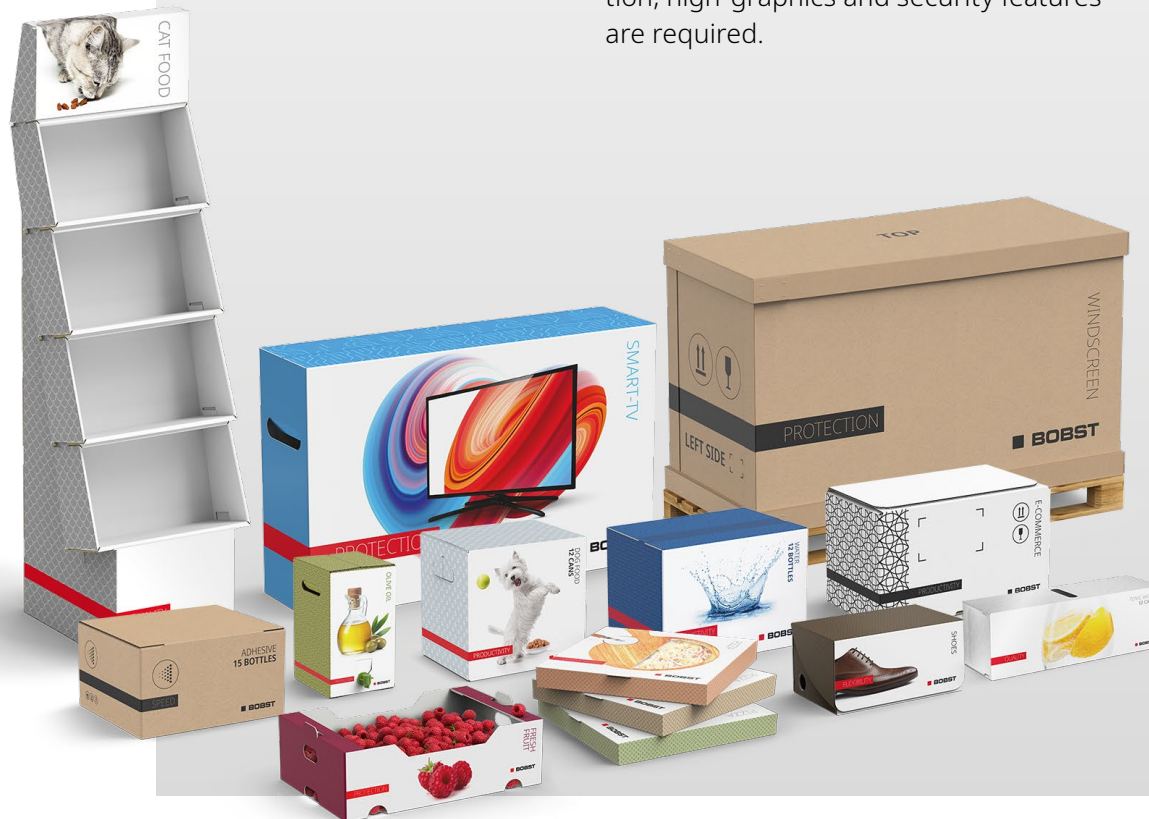

EXPERTFLUTE TOUCH

- > At a glance
- > Packaging market
 - > Corrugated board
 - > Folding carton
- > Benefits and features
 - > 1 – 3
- > Specifications
 - > Measurements
 - > Configurations
 - > Technical information
 - > 3D view
- > Related Products
- > Services
 - > General services
 - > Bobst Connect

Print responsibly

Data is not binding.
Non-contractual pictures.
The manufacturer reserves
the right to make modifica-
tions without notice.
© BOBST S.A. 2023
BUSF-EXFLU-EN-1123

Creating value

BOBST innovations
are driven by customer
and brand owner needs.

> READ MORE

Functional packaging and protection

Protecting the goods in a clever way is required. Single serve, multi-packs, re-sealable, see-through.

Customization, versioning, personalization

Packaging needs to reach all segments of the society taking almost any shape and size from very short runs to reprint and long runs. All with the best color consistency.

e-commerce & omni-channels

Multiple retail formats set new requirements for packaging. On-demand production, timely delivery across multiple designs, shapes and sizes.

Sustainability

Packaging production needs to reduce its environmental carbon footprint – less waste across the entire supply chain. New and thinner substrates. Recycling and re-use are the new rules.

Faster time-to-market

A growing number of products need to reach consumers faster. Product lifetime is shorter. From product design to the consumer experience, the supply chain has to be more agile.



EXPERTFLUTE TOUCH

- > At a glance
- > Packaging market
 - > Corrugated board
 - > Folding carton
- > Benefits and features
 - > 1 – 3
- > Specifications
 - > Measurements
 - > Configurations
 - > Technical information
 - > 3D view
- > Related Products
- > Services
 - > General services
 - > Bobst Connect

Print responsibly

Data is not binding.
Non-contractual pictures.
The manufacturer reserves
the right to make modifica-
tions without notice.
© BOBST S.A. 2023
BUSF-EXFLU-EN-1123

Benefits and features 1 - 3



Delivery system

VARIOSTACKER

- MATIC non-stop function
- Excellent stack quality
- Sheet count option
- MATIC set-up option
- Custom tailored solutions



Ultra-reliable precision

GAPRO glue unit

- Precise and easy glue dosing
- Continuously controlled glue gap
- Significant reduction in glue consumption
- Better laminated sheet quality – less wash-boarding,
- improved flatness
- Reduced laminated board humidity
- Curing time reduction, improved converting efficiency
- Cuts makeready time by recalling parameters from memory
- Easy cleaning with semi-automatic wash-up program



Centralized operation

Control desk

- Touch screen operating panel
- Enabling quality-control systems to be included
- Production administration software package with statistical data capturing

EXPERTFLUTE TOUCH

- > At a glance
- > Packaging market
 - > Corrugated board
 - > Folding carton
- > Benefits and features
 - > 1 - 3
- > Specifications
 - > Measurements
 - > Configurations
 - > Technical information
 - > 3D view
- > Related Products
- > Services
 - > General services
 - > Bobst Connect

 Print responsibly

Data is not binding.
Non-contractual pictures.
The manufacturer reserves the right to make modifications without notice.
© BOBST S.A. 2023
BUSF-EXFLU-EN-1123

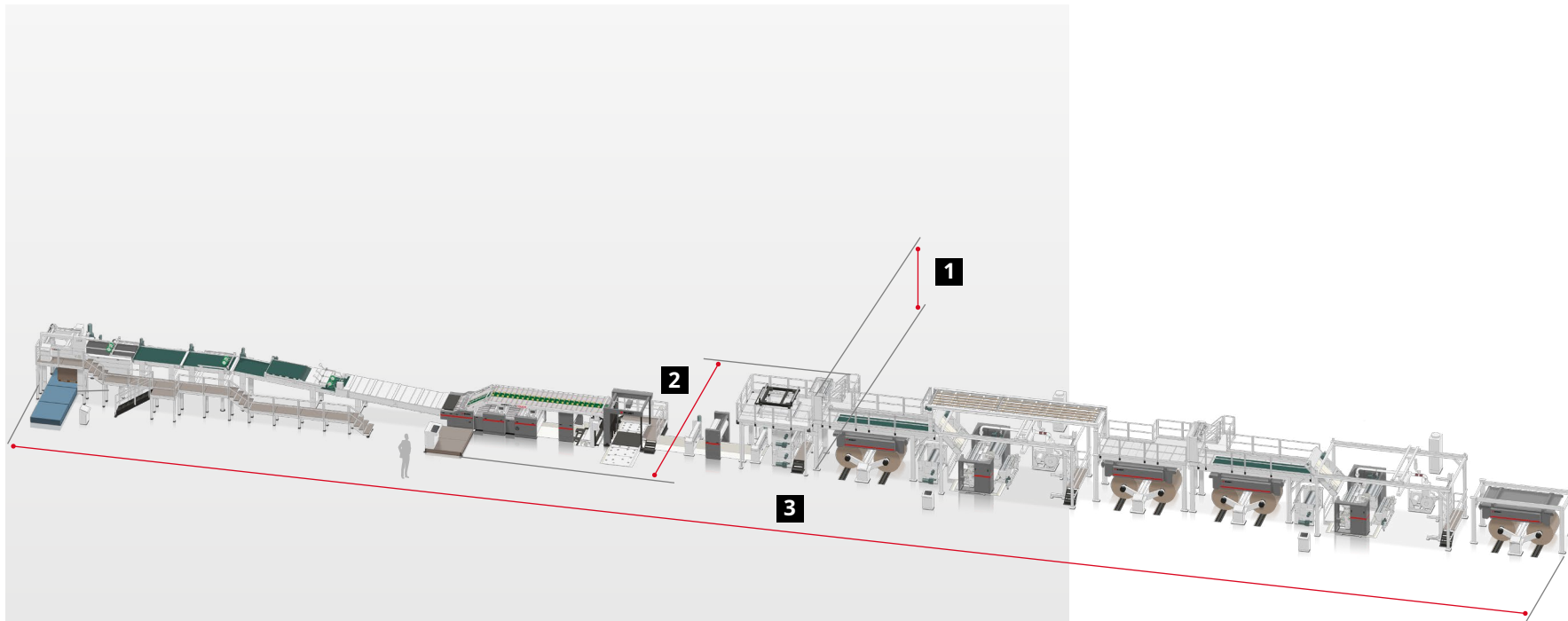

EXPERTFLUTE TOUCH

- > At a glance
- > Packaging market
 - > Corrugated board
 - > Folding carton
- > Benefits and features
 - > 1 - 3
- > Specifications
 - > Measurements
 - > Configurations
 - > Technical information
 - > 3D view
- > Related Products
- > Services
 - > General services
 - > Bobst Connect

1

Customer specific *

2

Customer specific *

3

Customer specific *

* Values may vary according to the configuration.

Print responsibly

Data is not binding.
 Non-contractual pictures.
 The manufacturer reserves
 the right to make modifica-
 tions without notice.
 © BOBST S.A. 2023
 BUSF-EXFLU-EN-1123

EXPERTFLUTE TOUCH 150

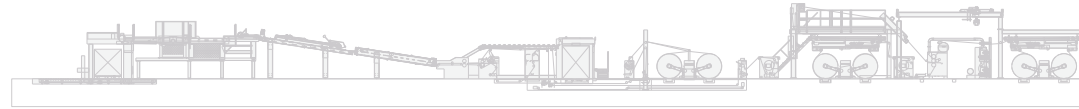

EXPERTFLUTE TOUCH 180

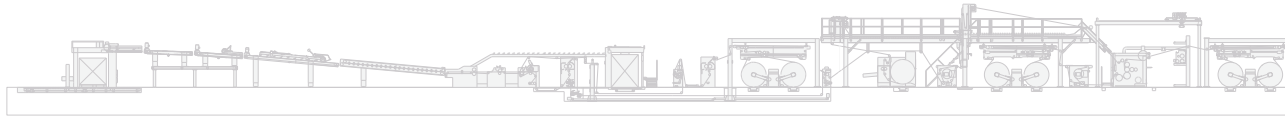

EXPERTFLUTE TOUCH 180

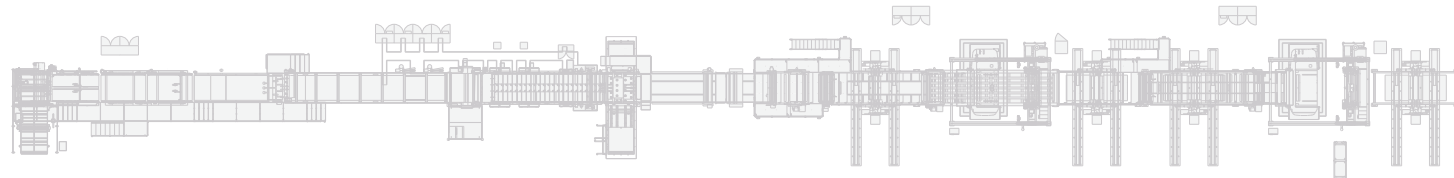
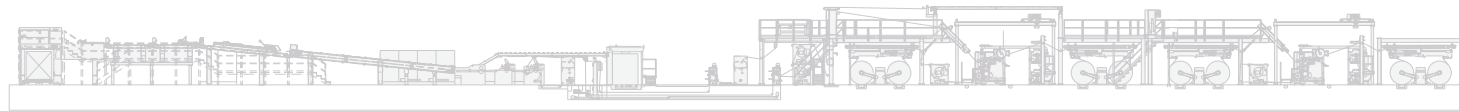

EXPERTFLUTE TOUCH

- > At a glance
- > Packaging market
 - > Corrugated board
 - > Folding carton
- > Benefits and features
 - > 1 – 3
- > Specifications
 - > Measurements
 - > Configurations
 - > Technical information
 - > 3D view
- > Related Products
- > Services
 - > General services
 - > Bobst Connect

 Print responsibly

Data is not binding.
Non-contractual pictures.
The manufacturer reserves
the right to make modifica-
tions without notice.
© BOBST S.A. 2023
BUSF-EXFLU-EN-1123

Convertible stock	EXPERTFLUTE TOUCH	
Singleface substrate caliper	0.5 to 6.6 mm	0.02 to 0.25 in
Litho sheet min. dimensions (w x l)	550 x 550 mm	22 x 22 in
Litho sheet max. dimensions (w x l)	1630 x 1650 mm	64 x 65 in
Litho sheet base weight min.	180g/m ²	37 lb/msf
Litho sheet base weight max.	400g/m ²	82 lb/msf

Performance *

Production speed	180 m/min	600 fpm
or	10,500 sh/hr	10,500 sh/hr

*depending on sheet length and configuration

Registration accuracy **

Laminating in-line direction	+/- 1 mm	+/- 0.04 in
Transverse direction	+/- 1 mm	+/- 0.04 in

** to one sheet side only

Performance

EXPERTFLUTE TOUCH

- > At a glance
- > Packaging market
 - > Corrugated board
 - > Folding carton
- > Benefits and features
 - > 1 – 3
- > Specifications
 - > Measurements
 - > Configurations
 - > Technical information
 - > 3D view
- > Related Products
- > Services
 - > General services
 - > Bobst Connect

**REQUEST
CONSULTING**

 Print responsibly

Data is not binding.
Non-contractual pictures.
The manufacturer reserves
the right to make modifica-
tions without notice.
© BOBST S.A. 2023
BUSF-EXFLU-EN-1123

Specifications - 3D view

Left side view



Right side view



EXPERTFLUTE TOUCH

- > At a glance
- > Packaging market
 - > Corrugated board
 - > Folding carton
- > Benefits and features
 - > 1 - 3
- > Specifications
 - > Measurements
 - > Configurations
 - > Technical information
 - > 3D view
- > Related Products
- > Services
 - > General services
 - > Bobst Connect

**REQUEST
CONSULTING**

 Print responsibly

Data is not binding.
Non-contractual pictures.
The manufacturer reserves
the right to make modifica-
tions without notice.
© BOBST S.A. 2023
BUSF-EXFLU-EN-1123

Related products



TRIPLO Glue unit

Option for double wall litho laminating. Excellent offset quality on double-wall board.



Reel stand ARS & splicer ARES III

Allows non-stop reel change at full speed.

- Zero tail web connection
- Driven carrier option
- Splice detection & ejection (option)
- Laser pointer reel centering



> MODULE FACER MF 324

Offers an unlimited range of flute profiles.

- Traction roll system for highest single-face quality
- Fully retractable glue unit for easy maintenance
- Temperature control of both paper liners via sensor and preheater
- Remote control of the laminator or the MF in production, in conjunction with the optional safety camera system



> MODULE FACER MF 260

Offers an unlimited range of flute profiles.

- Fully retractable glue unit for easy maintenance

EXPERTFLUTE TOUCH

- > At a glance
- > Packaging market
 - > Corrugated board
 - > Folding carton
- > Benefits and features
 - > 1 - 3
- > Specifications
 - > Measurements
 - > Configurations
 - > Technical information
 - > 3D view
- > Related Products
- > Services
 - > General services
 - > Bobst Connect

 Print responsibly

Data is not binding.
Non-contractual pictures.
The manufacturer reserves the right to make modifications without notice.
© BOBST S.A. 2023
BUSF-EXFLU-EN-1123

Maintaining excellence

Expert services for all your equipment.
Improve your processes, boost your productivity and enhance your expertise with a complete range of services from BOBST.



Maintenance Plus

- Scheduled maintenance with BOBST certified technicians
- Preventative intervention, maximizing machine uptime
- Optimum performance over the equipment lifetime

> WATCH VIDEO

Approved parts and logistics

- BOBST Original and Certified parts, and consumables
- Quality assurance, and extended maintenance intervals
- Worldwide distribution, and full availability where and when you need it

> LEARN MORE

Machine upgrades

- Additional features, configured for your machine
- Enhanced functionality, connectivity and capability
- Future-proofing your investment, maintaining competitive advantage

> LEARN MORE

EXPERTFLUTE TOUCH

- > At a glance
- > Packaging market
 - > Corrugated board
 - > Folding carton
- > Benefits and features
 - > 1-3
- > Specifications
 - > Measurements
 - > Configurations
 - > Technical information
 - > 3D view
- > Related Products
- > Services
 - > General services
 - > Bobst Connect

Print responsibly

Data is not binding.
Non-contractual pictures.
The manufacturer reserves the right to make modifications without notice.
© BOBST S.A. 2023
BUSF-EXFLU-EN-1123

Digital age manufacturing happening with BOBST Connect

BOBST Connect is an end-to-end, user-centric digital platform that enhances and increases your packaging productivity. It's designed to help you make the most of the data your machine generates, improving efficiency across your value chain.

As well as exceptional data insights, BOBST Connect helps to orchestrate and improve your whole production process, from your PDF to the finished product and quality report. It brings data and digital services together in one fully connected platform, with machine insights and expertise built in.

All of this is available to you as part of BOBST Connect Essential, the first subscription level that you receive when you purchase a new BOBST machine.

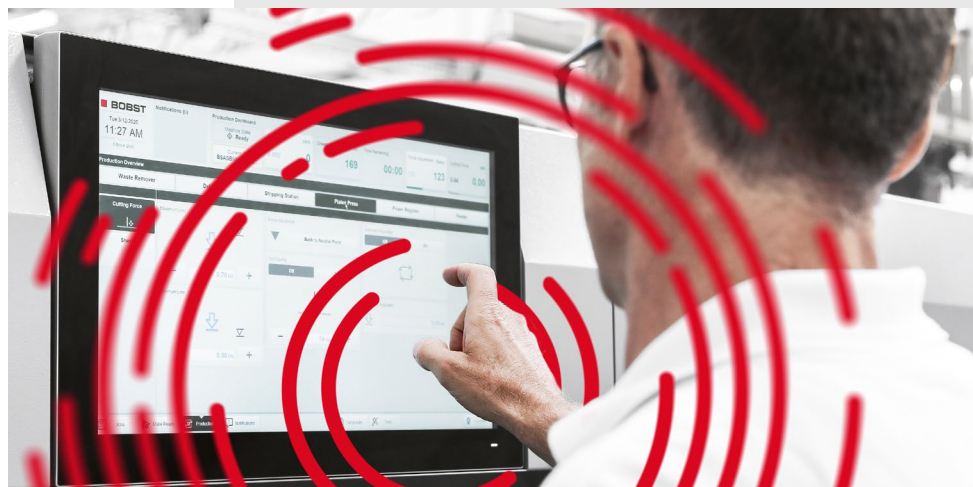

Performance analysis

- Production insights, including interaction of OEE components
- Identify and eliminate performance gaps

Accurate reporting

- Meaningful insights on OEE and downtime
- Accurately measure target speed and quality losses
- Trend analysis over time

Progress indicator

- Highlights extensive production deviations
- Empowers timely interventions

Remote assistance

- Priority access to technical specialists
- Video with Augmented Reality expert support based on real-time data
- Available 24/7 (optional)

Shift management

- Optimize planning time
- Deliver overall resource efficiency

EXPERTFLUTE TOUCH

- > At a glance
- > Packaging market
 - > Corrugated board
 - > Folding carton
- > Benefits and features
 - > 1-3
- > Specifications
 - > Measurements
 - > Configurations
 - > Technical information
 - > 3D view
- > Related Products
- > Services
 - > General services
 - > Bobst Connect

REQUEST SERVICE INFORMATION

 Print responsibly

Data is not binding.
Non-contractual pictures.
The manufacturer reserves the right to make modifications without notice.
© BOBST S.A. 2023
BUSF-EXFLU-EN-1123

Powering performance



LAMINATED BOARD | DEVICE

MODULE FACER MF260

At a glance

Boosting productivity

The **MF 260** is our answer to the market's need for superior quality corrugated for high graphics. Unlimited range of flute profiles for light to heavy weight paper. Wear resistant corrugating rolls (Chrome or Tungsten carbide)

MODULE FACER MF 260

- > At a glance
- > Benefits and features
 - > 1-3
 - > 4-6
- > Specifications
 - > Technical information

Non-stop productivity

Speed, precision and efficiency

Easy & safe accessibility

WATCH VIDEO

REQUEST CONSULTING

 Print responsibly

Data is not binding. Non-contractual pictures. The manufacturer reserves the right to make modifications without notice. © BOBST S.A. 2023 BUSF-EXFLU-EN-1123

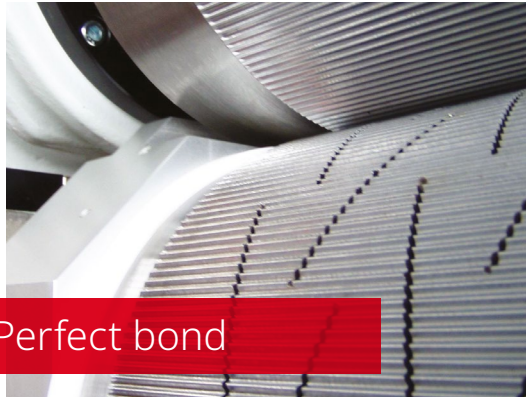

Perfect bond

Air drive system

- The best vacuum holding system
- Improved board quality, reduced risk of fluff-out
- Running off-center is possible
- Low maintenance
- Herring bone or radial slots available



Quick cassette change

Cassette change system

- Cassettes can be changed in just a few minutes with the handling system
- Manual trolley optionally available



Minimized space requirement

Cassette storage

- Integrated storage rack for three cassettes
- Safe and compact design

MODULE FACER MF 260

- > At a glance
- > Benefits and features
 - > 1-3
 - > 4-6
- > Specifications
 - > Technical information

 Print responsibly

Data is not binding.
Non-contractual pictures.
The manufacturer reserves the right to make modifications without notice.
© BOBST S.A. 2023
BUSF-EXFLU-EN-1123



Operator friendly

Easy handling

- Fully retractable glue unit
- MATIC glue dams, set to paper width
- Manual selectable steamshower
- Optional matic wrap arm control

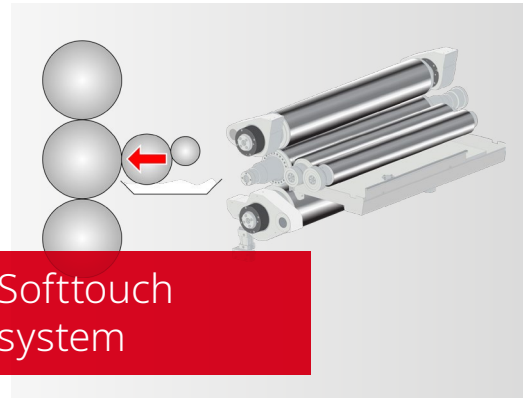

Softtouch system

Applicator system

- Self-adjusting applicator roll
- No more gap setting by operator
- Uniform glue application across the full width
- Fully retractable unit for easy maintenance



Intuitive control

Control panel

- Full management of your machine by color touchscreen with graphic mode, no text
- BOBST Connect

MODULE FACER MF 260

- > At a glance
- > Benefits and features
 - > 1-3
 - > 4-6
- > Specifications
 - > Technical information

Convertible stock	MODULE FACER MF 260	
Working width max.	1650 mm	65 in
Working width min. *	700mm	27.5 in
Production speed max.	150 m/min	500 fpm
Corrugating roll diameter	250 mm	10 in
Pressure roll diameter	400 mm	15.7 in
Steam pressure max.	15 bar ²	218 psi
Flute profile	C, B, E, F, N, G, R, D	
Paper gap	self-adjusting SOFT TOUCH system	
Glue gap adjustment	automatic speed related	
Vacuum system	AIR DRIVE, herring bone or radial slots	
*500mm possible with restrictions		

Space requirements

(w x l x h)	6800 x 6000 x 3600 mm	268 x 236 x 142 in
-------------	-----------------------	--------------------

FRONT VIEW

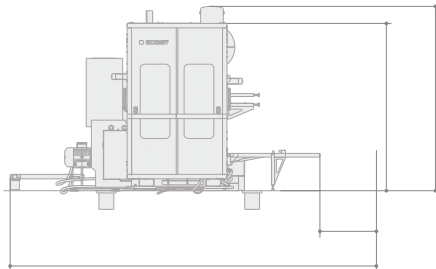

TOP VIEW

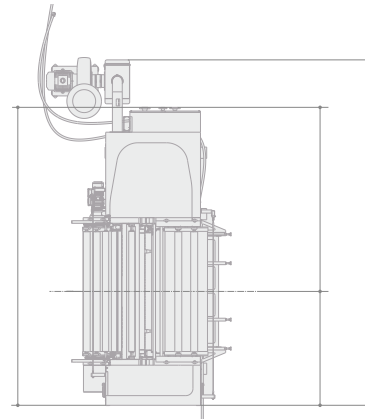

MODULE FACER MF 260

- > At a glance
- > Benefits and features
 - > 1-3
 - > 4-6
- > Specifications
 - > Technical information

REQUEST CONSULTING

Print responsibly

Data is not binding.
 Non-contractual pictures.
 The manufacturer reserves the right to make modifications without notice.
 © BOBST S.A. 2023
 BUSF-EXFLU-EN-1123

Powering performance



LAMINATED BOARD | DEVICE

MODULE FACER MF324

At a glance

BOBST

Boosting productivity

The **MF 324** is our answer to the market's need for superior quality corrugated for high graphics. Unlimited range of flute profiles for light to heavy weight paper with traction roll system for highest single face quality by increased nip
Wear resistant corrugating rolls (Chrome or Tungsten carbide)

MODULE FACER MF 324

- > At a glance
- > Benefits and features
 - > 1-3
 - > 4-6
- > Specifications
 - > Technical information

Non-stop productivity

Speed, precision and efficiency

Easy & safe accessibility

REQUEST CONSULTING

 Print responsibly

Data is not binding.
Non-contractual pictures.
The manufacturer reserves the right to make modifications without notice.
© BOBST S.A. 2023
BUSF-EXFLU-EN-1123

Page 19/23

Benefits and features 1 - 3

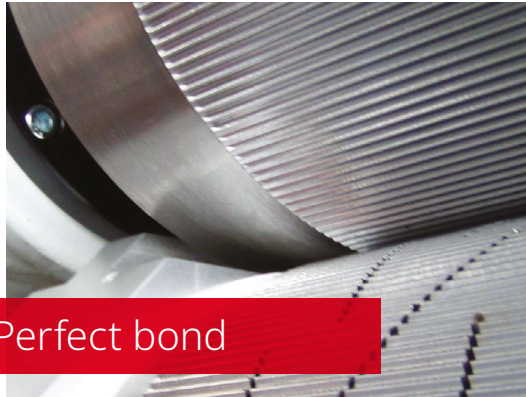

Perfect bond

Air drive system

- The best vacuum holding system
- Improved board quality, reduced risk of fluff-out
- Running off-center is possible
- Low maintenance
- Herring bone or radial slots available

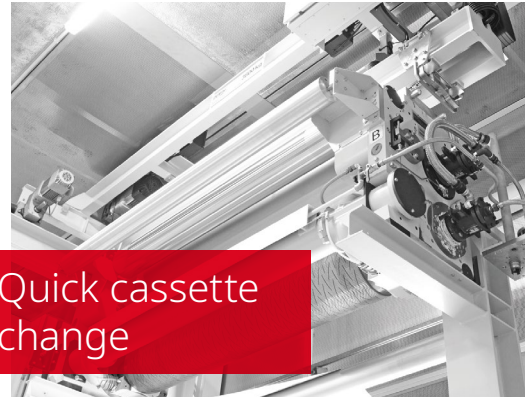

Quick cassette change

Cassette change system

- Cassettes can be changed in just a few minutes with the handling system
- Manual trolley optionally available



Minimized space requirement

Cassette storage

- Integrated storage rack for three cassettes
- Safe and compact design

MODULE FACER MF 324

- > At a glance
- > Benefits and features
 - > 1-3
 - > 4-6
- > Specifications
 - > Technical information

 Print responsibly

Data is not binding.
Non-contractual pictures.
The manufacturer reserves
the right to make modifica-
tions without notice.
© BOBST S.A. 2023
BUSF-EXFLU-EN-1123



Enhanced visual quality

Traction roll system

- Virtually eliminates press roll marks
- Provides increased burst strength to the finished product
- Enhances the visual appearance

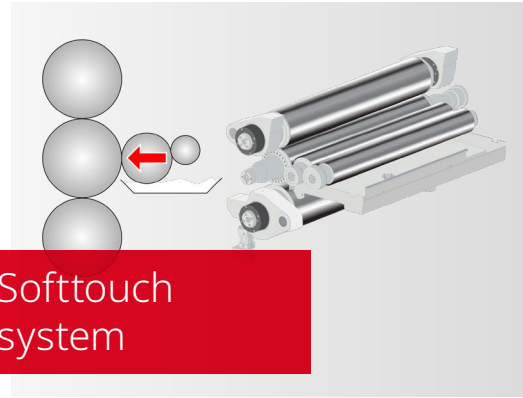

Softtouch system

Applicator system

- Self-adjusting applicator roll
- No more gap setting by operator
- Uniform glue application across the full width
- Fully retractable unit for easy maintenance
- MATIC glue dams, set to paper width



Intuitive control

Control panel

- Full management of your machine by color touchscreen with graphic mode, no text
- BOBST Connect

MODULE FACER MF 324

- > At a glance
- > Benefits and features
 - > 1-3
 - > 4-6
- > Specifications
 - > Technical information

 Print responsibly

Data is not binding.
Non-contractual pictures.
The manufacturer reserves the right to make modifications without notice.
© BOBST S.A. 2023
BUSF-EXFLU-EN-1123

Convertible stock	MODULE FACER MF 324	
Working width max.	1650 mm	65 in
Working width min. *	700mm	27.5 in
Production speed max.	220 m/min	720 fpm
Corrugating roll diameter	305 mm	12 in
Pressure roll diameter	400 mm	15.7 in
Steam pressure max.	15 bar ²	218 psi
Flute profile	C, B, E, F, N, G, R, D	
Paper gap	self-adjusting SOFT TOUCH system	
Glue gap adjustment	automatic speed related	
Vacuum system	AIR DRIVE, herring bone or radial slots	
Traction roll system	Separately driven	

*500mm possible with restrictions

Space requirements

(w x l x h)	6800 x 6000 x 3600 mm	268 x 236 x 142 in
-------------	-----------------------	--------------------

MODULE FACER MF 324

- > At a glance
- > Benefits and features
 - > 1–3
 - > 4–6
- > Specifications
 - > Technical information

**REQUEST
CONSULTING**

 Print responsibly

Data is not binding.
Non-contractual pictures.
The manufacturer reserves
the right to make modifica-
tions without notice.
© BOBST S.A. 2023
BUSF-EXFLU-EN-1123

Market-leading excellence

> WWW.BOBST.COM/EXPERTFLUTE TOUCH

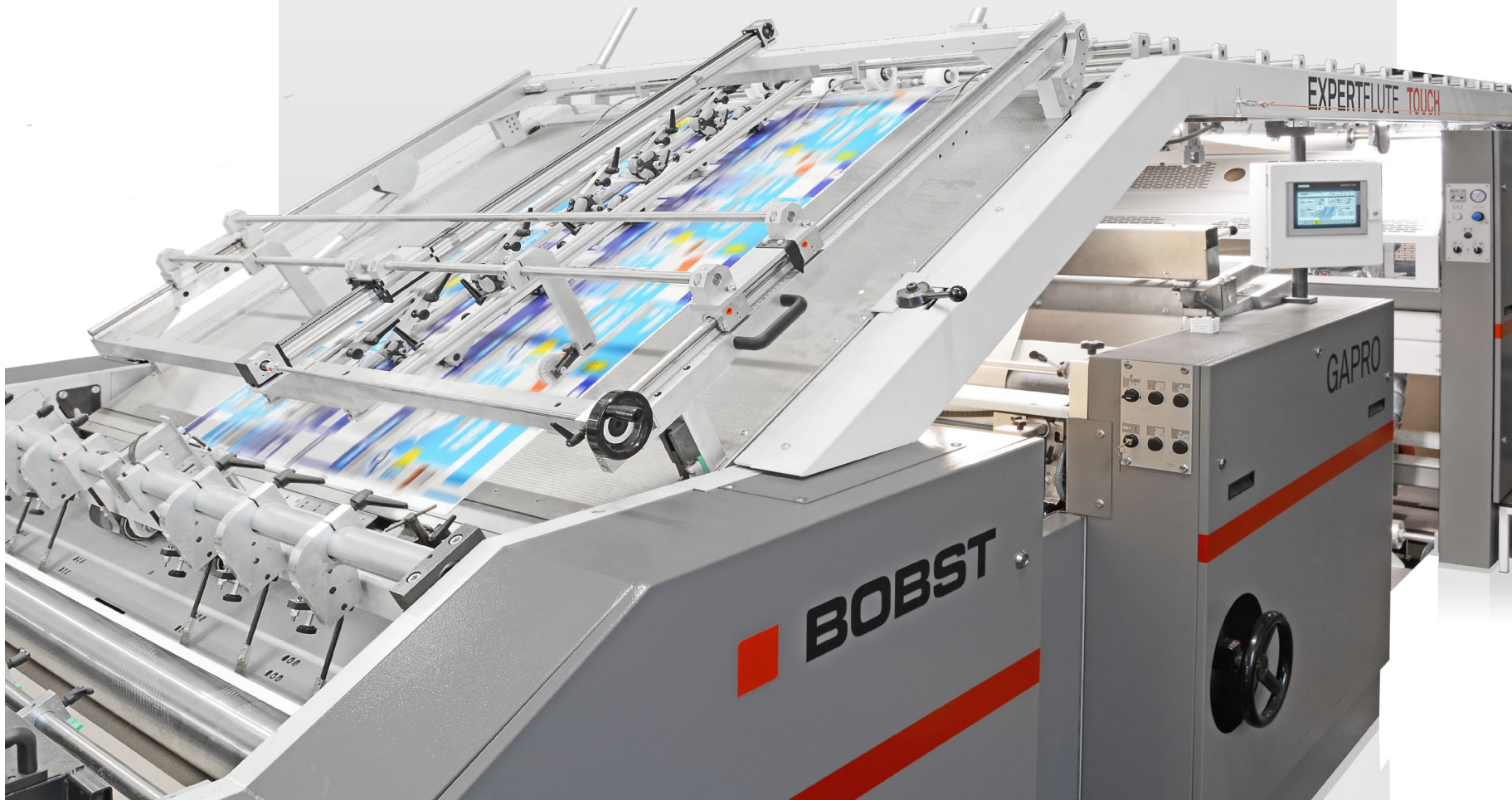

EXPERTFLUTE TOUCH

- > At a glance
- > Packaging market
 - > Corrugated board
 - > Folding carton
- > Benefits and features
 - > 1-3
- > Specifications
 - > Measurements
 - > Configurations
 - > Technical information
 - > 3D view
- > Related Products
- > Services
 - > General services
 - > Bobst Connect

REQUEST
CONSULTING

 Print responsibly

Data is not binding.
Non-contractual pictures.
The manufacturer reserves
the right to make modifica-
tions without notice.
© BOBST S.A. 2023
BUSF-EXFLU-EN-1123